

08404 Dual Radio Audio Interface

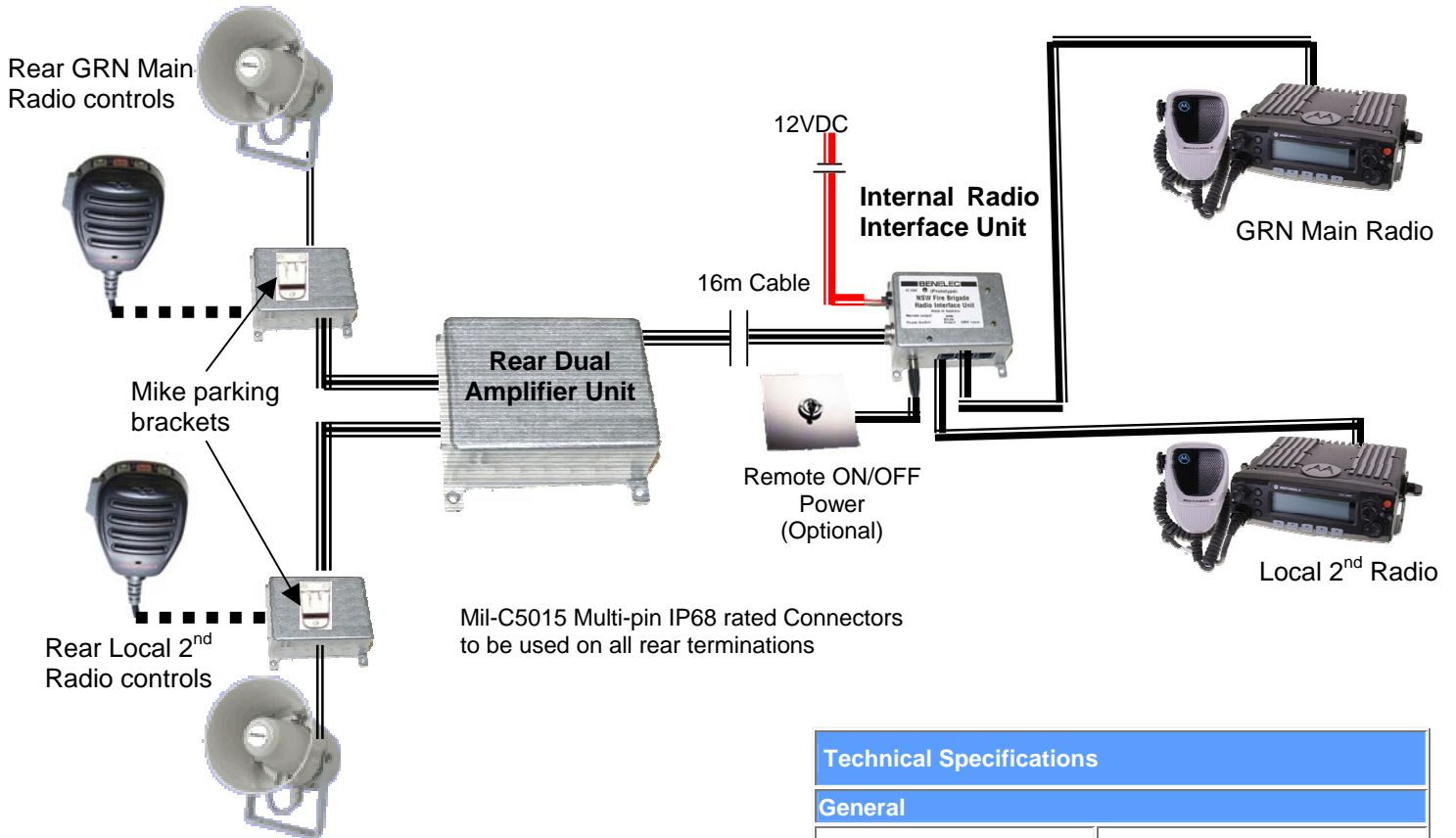

Main Features

- IP68 Rated Solution at rear of vehicle *
- 2 x 11 W Amplified Audio Output
- Output Gain adjustable for both mikes
- Bright Power on LED in for each rear Remote Unit
- IP68 rated Die cast housings
- IP68 Three button control Mike w/ integrated Speaker
- Internal + External ON / OFF Switch controls
- Integrated Stainless Mike Parking Brackets
- Up to 16m cable between Front & rear of vehicle
- Rugged IP68 rated Mil Spec connectors Mil-5015C
- Configurable for any brand and model of radio
- Balanced Audio between front and rear Amplifier

Configurable Features

- 1) Minimum Output Volume Level
- 2) Mike Speaker Levels
- 3) MDC1200 Decode & Display
- 4) TOT – Time out timer
- 5) LED Status indications
- 6) Microphone input and output levels software configurable

Technical Specifications	
General	
Input Voltage – Internal radio Interface unit	11-14.5 V
Current (Approx)	2.8 amp @ full power
Amplifier	
Output	2 x 11W rms
Drive	50mV for 11W (volume full)
Volume Control via rear mike Buttons up and down	10 steps 6dB / steps
PA Horn Speaker	8Ω 25w rated
Microphone	
Water proof electrets	
Microphone Amplifier	
Output Impedance	600 Ω
Output level	Up to 2000mV p-p (adjustable)
Frequency response	300Hz – 8000Hz
Audio Interface Balanced signal lines (transformers at each end)	

Block Diagram Rear Unit

